



HITACHI

CUT-OFF MACHINE

TYPE 305mm (12") CC 12
355mm (14") CC 14

INSTRUCTION MANUAL

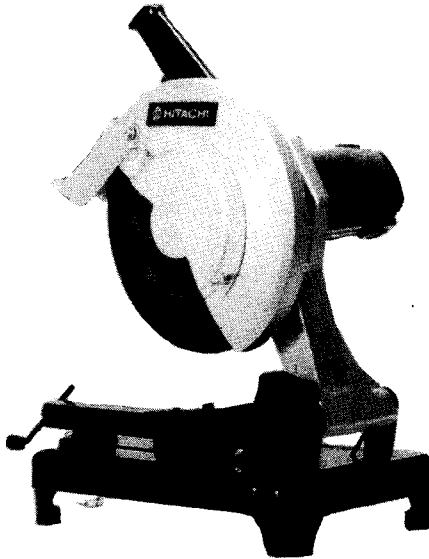

Note:

Before using this Electric Power Tool, carefully read through this INSTRUCTION MANUAL to ensure efficient safe operation. It is recommended that this MANUAL be kept readily available as an important reference when using this electric power tool.



DOUBLE INSULATION

We sincerely thank you for selecting a HITACHI ELECTRIC POWER TOOL. To operate this electric power tool safely and efficiently, please read this INSTRUCTION MANUAL carefully to get a good understanding of the precautions in operation, the capacity of the electric power tool, uses and the like.

IMPORTANT INFORMATION: SAFETY RULES FOR POWER TOOLS

WARNING: When using electric tools, basic safety precautions should always be followed to reduce the risk of fire, electric shock, and personal injury, including the following.

READ ALL INSTRUCTIONS

1. **KEEP WORK AREA CLEAN.** Cluttered areas and benches invite injuries.
2. **CONSIDER WORK AREA ENVIRONMENT.**
 - Don't expose power tools to rain.
 - Don't use power tools in damp or wet locations.
 - Keep work area well lit.
 - Don't use tool in presence of flammable liquids or gases.
 - Power tools produce sparks during operation. They also spark when switching ON/OFF. Never use power tools in dangerous sites containing lacquer, paint, benzine, thinner, gasoline, gases, adhesive agents, and other materials which are combustible or explosive.
3. **GUARD AGAINST ELECTRIC SHOCK.** Prevent body contact with grounded surfaces. For example, pipes, radiators, refrigerator enclosures.
4. **KEEP CHILDREN AWAY.** Do not let visitors contact tool or extension cord. All visitors should be kept away from work area.
5. **STORE IDLE TOOLS.** When not in use, tools should be stored in dry, and high or locked-up place-out of reach of children.
6. **DON'T FORCE TOOL.** It will do the job better and safer at the rate for which it was intended.
7. **USE RIGHT TOOL.** Don't force small tool or attachment to do the job of a heavy-duty tool.
 - Don't use tool for purpose not intended-for example-don't use circular saw for cutting tree limbs or logs.
8. **DRESS PROPERLY.** Do not wear loose clothing or jewelry. They can be caught in moving parts.
 - Rubber gloves and non-skid footwear are recommended when working outdoors.
 - Wear protective hair covering to contain long hair.
9. **USE SAFETY GLASSES.** Also use face or dust mask if cutting operation is dusty.
10. **DON'T ABUSE CORD.** Never carry tool by cord or yank it to disconnect from receptacle. Keep cord from heat, oil, and sharp edges.

11. **SECURE WORK.** Use clamps or a vise to hold work. It's safer than using your hand and it frees both hands to operate tool.
12. **DON'T OVERREACH.** Keep proper footing and balance at all times.
13. **MAINTAIN TOOLS WITH CARE** Keep tools sharp and clean for better and safer performance.
Follow instructions for lubricating and changing accessories.
Inspect tool cords periodically and if damaged, have repaired by authorized service facility.
Inspect extension cords periodically and replace if damaged.
Keep handles dry, clean, and free from oil and grease.
14. **DISCONNECT TOOLS.** When not in use, before servicing, and when changing accessories, such as blades, bits, cutters.
15. **REMOVE ADJUSTING KEYS AND WRENCHES.** Form habit of checking to see that keys and adjusting wrenches are removed from tool before turning it on.
16. **AVOID UNINTENTIONAL STARTING.** Don't carry plugged-in tool with finger on switch. Be sure switch is off when plugging in.
17. **OUTDOOR USE EXTENSION CORDS.** When tool is used outdoors, use only extension cords intended for use outdoors and so marked.
18. **STAY ALERT.** Watch what you are doing. Use common sense. Do not operate tool when you are tired.
19. **CHECK DAMAGED PARTS.** Before further use of the tool, a guard or other part that is damaged should be carefully checked to determine that it will operate properly and perform its intended function. Check for alignment of moving parts, binding of moving parts, breakage of parts, mounting, and any other conditions that may affect its operation. A guard or other part that is damaged should be properly repaired or replaced by an authorized service center unless otherwise indicated elsewhere in this instruction manual.
Have defective switches replaced by authorized service center.
Do not use tool if switch does not turn it on and off.
20. **AVOID USING A POWER TOOL FOR APPLICATIONS OTHER THAN THOSE SPECIFIED.** Never use a power tool for applications other than those specified in the instruction manual.
21. **ENSURE SAFE OPERATION THROUGH CORRECT HANDLING.** Secure safe operation through correct handling by observing the instructions described herein.
Do not employ accessories other than those specified herein; otherwise, a hazardous condition may be created.
Never allow a power tool to be used by persons not familiar with correct handling (such as children) or by those who cannot handle the tool correctly.
22. **CONFIRM THAT NO ITEMS SUCH AS AN ELECTRIC CABLE OR CONDUIT ARE BURIED INSIDE.** In places where live wiring may be hidden behind a wall, floor, ceiling, etc, do not hold or contact any metal parts of the tool. In such cases, metal parts could become electrically live and present a serious shock hazard.

23. **KEEP THE RIGHT PARTS IN THE RIGHT POSITIONS.** Do not remove covers and screws which have been factory-mounted. They perform important respective roles. Keep them in the right positions.
24. **SHOULD THE PLASTIC HOUSING OR HANDLE OF A POWER TOOL BE CRACKED OR DEFORMED, DO NOT USE IT.** Since cracked or deformed parts may lead to an operator receiving an electric shock, do not use such a power tool. Immediately have it repaired.
25. **SECURELY MOUNT ACCESSORIES AND BLADES TO THE TOOL MAIN BODY.**
26. **ALWAYS KEEP THE MOTOR AIR VENT FULLY OPENED.** A constantly open motor air vent is necessary to allow air to come in and out for cooling the motor. Do not allow it to become clogged up, even if dust is blown through it.
27. **OPERATE POWER TOOLS AT THE RATED VOLTAGE.** Operate power tools at voltages specified on their nameplates.
28. **NEVER TOUCH THE MOVING PARTS.** Never touch the moving parts such as blades, bits, cutters and others.
29. **STOP OPERATION IMMEDIATELY IF ANY ABNORMALITY IS DETECTED.** Should a power tool be detected as out of order or should other abnormalities be observed during operation, stop using the tool immediately.
30. **NEVER LEAVE TOOL RUNNING UNATTENDED. TURN POWER OFF.** Don't leave tool until it comes to a complete stop.
31. **CAREFULLY HANDLE POWER TOOLS.** Should a power tool be dropped or struck against hard materials inadvertently, it may be deformed, cracked, or damaged.
32. **DO NOT WIPE PLASTIC PARTS WITH SOLVENT.** Solvents such as gasoline, thinner, benzene, carbon tetrachloride, and alcohol may damage and crack plastic parts. Do not wipe them with such solvents. Wipe plastic parts with a soft cloth lightly dampened with soapy water.
33. **WHEN REPLACING A COMPONENT PART, ADOPT THE SAME TYPE.**
When replacing a component part with a new one, adopt the same type of new part. Also, never attempt to repair a power tool yourself.

SAVE THESE INSTRUCTIONS

SERVICE AND REPAIRS

All quality tools will eventually require servicing or replacement of parts due to wear from normal use. These operations should **ONLY** be performed by an **AUTHORIZED HITACHI POWER TOOL REPAIR SHOP.**

DOUBLE INSULATION SYSTEM ENHANCES SAFE OPERATION

To enhance safe operation of this electric power tool, HITACHI has adopted a double insulation system. The term "double insulation" used here denotes an insulation system with two insulations physically separated and arranged between the electrically conductive material connected to the power supply and the outer frame subject to contact by the operator.

Thus, the power tool is termed double insulated and both the "□" mark and "Double insulation", or either one is indicated on the name plate.



While no external grounding is required with this system, normal safety precautions as outlined in this manual must still be followed. **DOUBLE INSULATION**

To maintain the effectiveness of the double insulation system, follow the precautions described below:

1. Always contact your dealer or an authorized HITACHI power tool repair shop when assembling, disassembling or replacing parts other than accessories or carbon brushes. Improper assembly and/or replacement with wrong parts may result in eliminating the double insulation-feature.
2. Clean the exterior of the tool with a soft cloth moistened with soapy water, and dry thoroughly. Chloric solvent, gasoline, and thinner will cause plastic components to dissolve.

REPLACEMENT PARTS

When servicing use only identical replacement parts.

PRECAUTIONS ON USING A CUT-OFF MACHINE

REGARDING THIS HITACHI CUT-OFF MACHINE, PAY PARTICULAR ATTENTION TO THE FOLLOWING.

1. Always apply a trial run.
2. Handle the cut-off wheel with care.
3. Start cutting only after motor revolution full speed.
4. Guard against cut-off sparks.
5. Keep hands out of the line of cut-off wheel.
6. Do not perform any operation freehand.
7. Never reach around or behind cut-off wheel.
8. Shut off power and wait for cut-off wheel to stop before servicing and adjusting tool.

NAMES OF COMPONENT PARTS

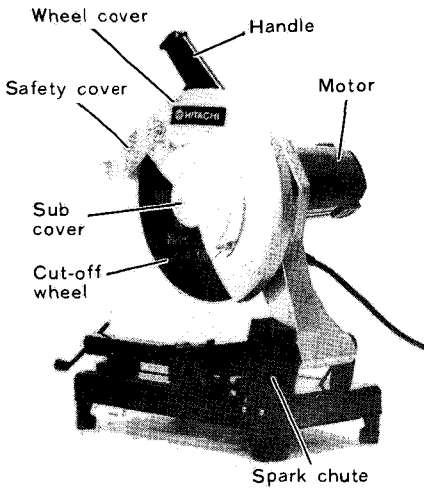

Fig. 1

TYPE CC12

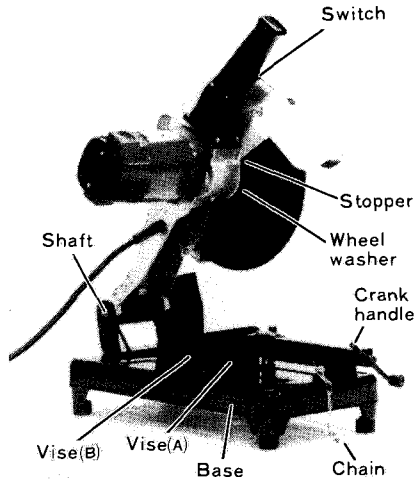

Fig. 2

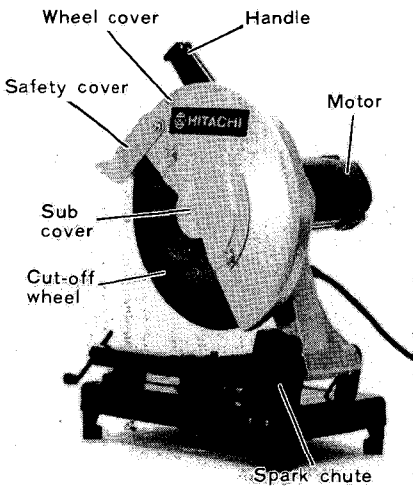

Fig. 3

TYPE CC14

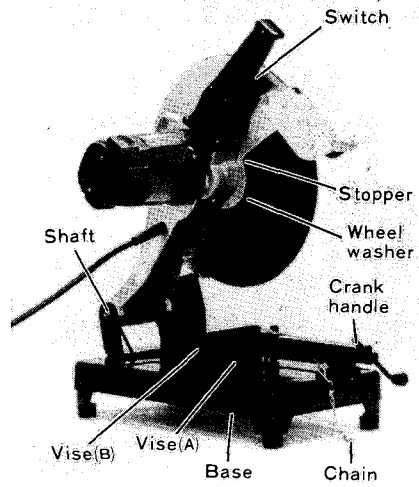

Fig. 4

SPECIFICATIONS

Item		Type	CC12	CC14
Motor	Type	Protected type, series wound commutator motor		
	Power source	Single-phase AC 60Hz		
	Voltage (V)	115		
	Full-load current (A)	15		
Cut-off wheel	Type	Reinforced resinoid cut-off wheel		
	Dimensions	Outside dia. 305mm (12") × thickness 2.8mm ($\frac{7}{64}$ ") × hole dia. 25.4mm (1")	Outside dia. 355mm (14") × thickness 2.8mm ($\frac{7}{64}$ ") × hole dia. 25.4mm (1")	
	Max. working peripheral speed	4800m/min (16000ft/min)		
No-load speed		4000rpm	3700rpm	
No-load peripheral speed		3832m/min (12570ft/min)	4125m/min (13540ft/min)	
Max. cutting demensions	90°	Max. height 100mm ($3\frac{59}{64}$ ")	Max. height 100mm ($3\frac{59}{64}$ ")	
		Max. width 100mm ($3\frac{59}{64}$ ")	Max. width 165mm ($6\frac{1}{2}$ ")	
	45°	Max. height 55mm ($2\frac{5}{32}$ ")	Max. height 55mm ($2\frac{5}{32}$ ")	
		Max. width 198mm ($7\frac{21}{64}$ ")	Max. width 236mm ($6\frac{3}{8}$ ")	
Max. opening of vise		236mm ($9\frac{3}{32}$ ")		
Weight		16kg (35lbs.)	17kg (37lbs.)	
Cord		2 core cabtyre cable 2.5m (8ft)		

STANDARD ACCESSORIES



Fig. 5

① Cut-off wheel 305×2.8×25.4mm (12"× $\frac{7}{64}$ "×1")
 Type CC12 (A36RBIG) 1pc. (Code No. 964949Z)
 (Attached to the main body)

Cut-off wheel 355×2.8×25.4mm (14"× $\frac{7}{64}$ "×1")
 Type CC14 (A36RBIG) 1pc. (Code No. 964975Z)
 (Attached to the main body)

② Spanner

[CUTION] The use of attachment or accessories not recommended in this manual may be hazardous.

APPLICATION

Cutting off the following materials:

- Round bars
- Various types of shaped steel
- Pipes
- Siding boards up to 236mm ($9\frac{9}{32}$ ") and so on.

PREPARATION PRIOR TO OPERATION

The following preparations shall be made before operation of cut-off machine.

1. Installation

Install the Machine on a level flat place, and keep it in a staddle condition.

2. Extension Cord:

When the power outlet is at some distance from the work area, ensure that an extension cord of appropriate length and amperage rating is utilized.

Amperage rating (on nameplate)	0 to 2.0	2.1 to 3.4	3.5 to 5.0	5.1 to 7.0	7.1 to 12.0	12.1 to 16.0
Ext. Cord length	Wire gauge size mm ² (A.W.G)					
7.5m (25ft.)	1.0mm ² (18A.W.G)	1. mm ² (18A.W.G)	1.0mm ² (18A.W.G)	1.0mm ² (18A.W.G)	1.5mm ² (16A.W.G)	2.0mm ² (14A.W.G)
15m (50ft.)	1.0mm ² (18A.W.G)	1. mm ² (18A.W.G)	1.0mm ² (18A.W.G)	1.5mm ² (16A.W.G)	2.0mm ² (14A.W.G)	3.5mm ² (12A.W.G)
22.5m (75ft.)	1.0mm ² (18A.W.G)	1. mm ² (18A.W.G)	1.5mm ² (16A.W.G)	2.0mm ² (14A.W.G)	3.5mm ² (12A.W.G)	5.5mm ² (10A.W.G)
30m (100ft.)	1.0mm ² (18A.W.G)	1. mm ² (16A.W.G)	2.0mm ² (14A.W.G)	3.5mm ² (12A.W.G)	5.5mm ² (10A.W.G)	—
45m (150ft.)	1.5mm ² (16A.W.G)	2. mm ² (14A.W.G)	3.5mm ² (12A.W.G)	3.5mm ² (12A.W.G)	—	—
60m (200ft.)	1.5mm ² (16A.W.G)	2. mm ² (14A.W.G)	3.5mm ² (12A.W.G)	5.5mm ² (10A.W.G)	—	—

3. Confirming condition of the environment

Confirm that the work site is placed under appropriate conditions conforming to prescribed precautions.

4. Take off the chain

As the movable part is pulled down by a chain when shipping out, please slightly push the handle down and take off the chain from the handle.

5. Clean and check the work place.

Check the work place whether it is in a proper condition as mentioned in the cautions.

BEFORE OPERATION

[Caution] Check the items mentioned below before operating the cut-off machine. Check the items 1~8 before the plug is inserted into the power outlet.

1. Confirm the applied power source

Be sure to operate the Cut-off machine in the voltage specified on the name plate.

[Caution] Do not use the D.C. power source otherwise the machine may be damaged.

2. Confirm that the power switch is turned OFF

If the plug is connected to the power supply while the power switch is turned ON, the machine starts operating unexpectedly, inviting serious accidents.

The switch is turned ON by pulling the switch trigger (see Fig. 2 and 4) and OFF by releasing the trigger.

Please confirm that the switch trigger is back at the original location when released.

3. Ascertain cut-off wheel condition

Ascertain that all cut-off wheels are in perfect condition, and do not display scars and cracks.

4. Ascertain clamping of the cut-off wheel

Although they have been fully clamped at the factory prior to delivery, reclamp the clamping bolt securely for safety. (See the item on Replacing the cut-off

wheel).

[Caution] When the clamping bolt is loosened, the cut-off wheel may be damaged when the wheel axle starts revolving, causing a hazardous condition.

5. Ascertain clamping of the protective cover

Possible accidents such as a cracked cut-off wheel is prevented by this protective cover (wheel cover).

Although it has been fully clamped at the factory prior to delivery, securely reclamp the mounting screws for safety.

[Caution] Confirm that the protective cover (wheel cover) is securely mounted.

6. Use cut-off wheels which peripheral speed ratings are over the maximum working peripheral speed.

When replacing the cut-off wheel, ensure that the replacement cut-off wheel has a designed peripheral speed in excess of 4800m/min(16000ft/min).

7. Confirm the stopper

Confirm that the stopper which was used for installation and removal of the cut-off wheel has returned to the retract position.

8. Securely fix the cutting material.

Ensure that the material is securely fastened with the vise. If it is not, a serious accident could be caused if the material comes loose or the cut-off wheel breaks during operation.

9. Confirm the power supply

If the power receptacle only loosely accepts the plug, the receptacle must be repaired. Contact the nearest electric store for repair service.

If such a faulty receptacle is used, it may cause overheating, resulting in a serious hazard.

10. Applying a trial run

Continued grinding without noticing a cracked or split cut-off wheel may prove to be very hazardous.

Before starting operation, temporarily step away from the front position and make a trial run to confirm that no abnormalities are involved.

Trial run periods:

When replacing the cut-off wheel Over 3 minutes.

When starting routine work Over 1 minute.

11. Inspect facial deflection of the Cut-off wheel

Rotate the Cut-off wheel to inspect any facial deflection. A heavy deflection will cause the Cut-off wheel to shift.

CUTTING PROCEDURES

[Caution] It is dangerous to remove or install the workpiece while the cut-off wheel turning.

1. Switch operation.

After pushing the lock-off button with the thumb, the tool is turned ON when the switch trigger is pulled, and OFF when the trigger switch is released.

2. Cutting

- (1) Rotate the cut-off wheel, gently press down the handle, and bring the cut-off wheel close to the cutting material.
- (2) When the cut-off wheel contacts the cutting material, gently press down the handle further and start cutting.
- (3) When cutting (or designated slotting) is completed, raise the handle and restore it to its original position.
- (4) At the termination of each cutting process, turn OFF the switch to stop rotation and proceed with the subsequent cutting job.

[Caution] It does not necessarily cut rapidly when putting more force on the handle.

Too much force on the handle will put excessive pressure on the motor and reduce its capacity.

Do not fail to turn OFF the switch after operation is completed and pull the plug out.

MOUNTING AND DISMOUNTING THE CUT-OFF WHEEL

[Caution] Be sure to switch OFF and have pulled the plug from the power outlet to prevent any possible accident.

1. Dismounting the Cut-off Wheel (Fig. 6)

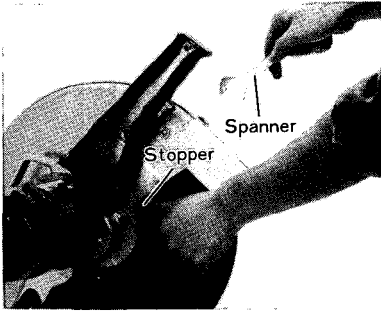

Fig. 6

(1) Press the stopper and loosen the bolt with a spanner.

[Caution] When the mounting shaft for cut-off wheel cannot be fixed with pressing the stopper, turn the bolt with a spanner while pressing the stopper.

The mounting shaft for cut-off wheel is fixed when the stopper has been lowered.

(2) Remove the bolt, washer(A), and the wheel washer and detach the cut-off wheel.

2. Mounting the Cut-off Wheel

Thoroughly remove dust from the wheel washers and bolt then mount the wheel by following the dismounting procedures in reverse order.

Be sure to attach the sub-cover at the end.

[Caution] Confirm that the stopper which was used for installation and removal of the cut-off wheel has returned to the retract position.

HOW TO OPERATE

1. Cutting at Angles (Figs. 7 and 8)

The machine permits cutting at angles of 45° or 60°.

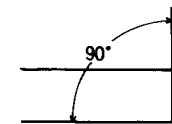

When setting at an angle of 0°

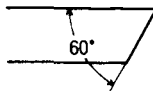

When setting at an angle of 30°

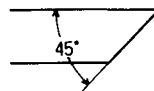

When setting at an angle of 45°

Fig. 7

Loosen the two 10mm($\frac{25}{64}$ ") bolts on the vise-jaw (B), then set the working surface on the vise-jaw at any angles of 0°, 30° or 45° as shown in Fig. 8.

Upon completion of setting, securely tighten the two 10mm($\frac{25}{64}$ ") bolts.

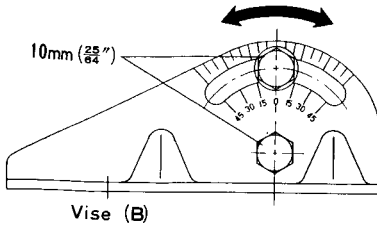

Fig. 9

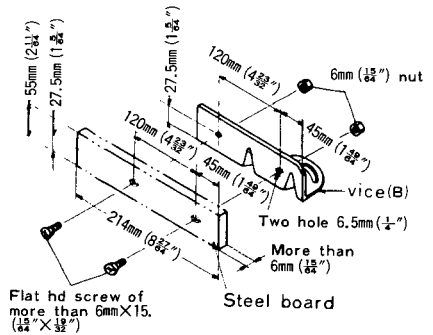

Fig. 8

When wide material is cut with angle, it will be firmly camped by fixing a steel board like Fig. 10 to the vise (B).

2. Moving the Stationary vise-jaw (Fig. 10)

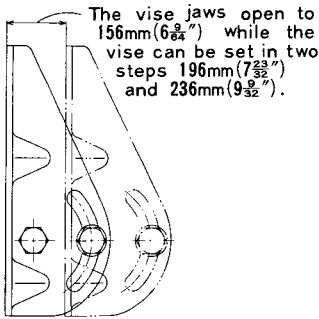

Fig. 10

The vise opening is set at the maximum of 156mm($6\frac{1}{4}$ ") when shipped from the factory.

In case of an opening more than 156mm($6\frac{1}{4}$ ") is required, move the vise-jaw to the position shown by the chain line after unscrewing the two bolts.

The maximum opening can be set in two steps 196mm($7\frac{3}{32}$ ") and 236mm($9\frac{9}{32}$ ").

When the cutting material is excessively wide, the vise can be effectively used by repositioning the stationary side of the vise jaws.

3. How to use Metallic Block (Fig. 11)

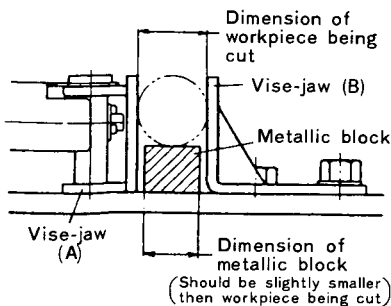

Fig. 11

When the cut-off wheel has a reduced outer diameter, insert between the vise-jaws (A) and (B) a metallic block slightly smaller than the dimension of workpiece being cut to use the cut-off wheel economically.

MAINTENANCE AND INSPECTION

[Caution] Be sure to switch off and pull off the plug from the power outlet before inspection and maintenance.

1. Replacing a cut-off wheel

When the cut-off wheel has already become dull while continually using, the unnecessary load is got from the motor.

Consequently, re-dress or replace a dull cut-off wheel to ensure cut-off efficiency.

2. Inspecting the carbon brushes.

The motor employs carbon brushes which are consumable parts. When they become worn to or near "wear limit", it could result in motor trouble. When an auto-stop carbon brush is equipped, the motor will stop automatically.

At that time, replace both carbon brushes with new ones which have the same carbon brush Nos. shown in Fig. 12.

In addition, always keep carbon brushes clean and ensure that they slide freely within the brush holders.

Replacing procedure for carbon brushes.

Disassemble the brush cap (see Fig. 13) with a minus screwdriver, the carbon brush can then be easily removed.

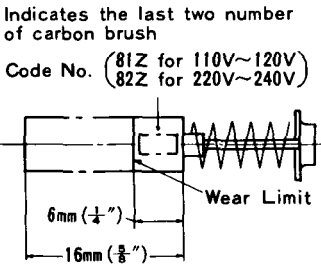

Fig. 12

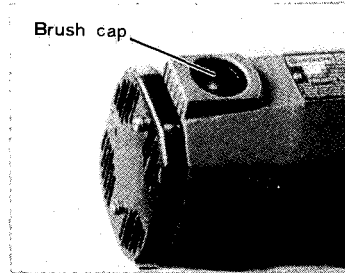

Fig. 13

3. Inspection of mounting screws.

Inspect regularly each part of the machine for looseness. Re-tighten it if there is any part loosened.

It is dangerous if the machine is operated with any part loosened.

4. Lubrication.

Supply oil in the following oil supply points once a month so as to keep the machine workable for a long time. (See Fig. 1, 2, 3 and 4)

(The machine oil is recommended.)

Oil supply point.

- Rotary part of shaft.
- Rotary part of vise.
- Slide way of vise-jaw (A).

5. Cleaning.

Wipe off chip and waste adhered to the machine with a cloth or the like time to time. Be careful not to make the motor portion wet with oil or water.

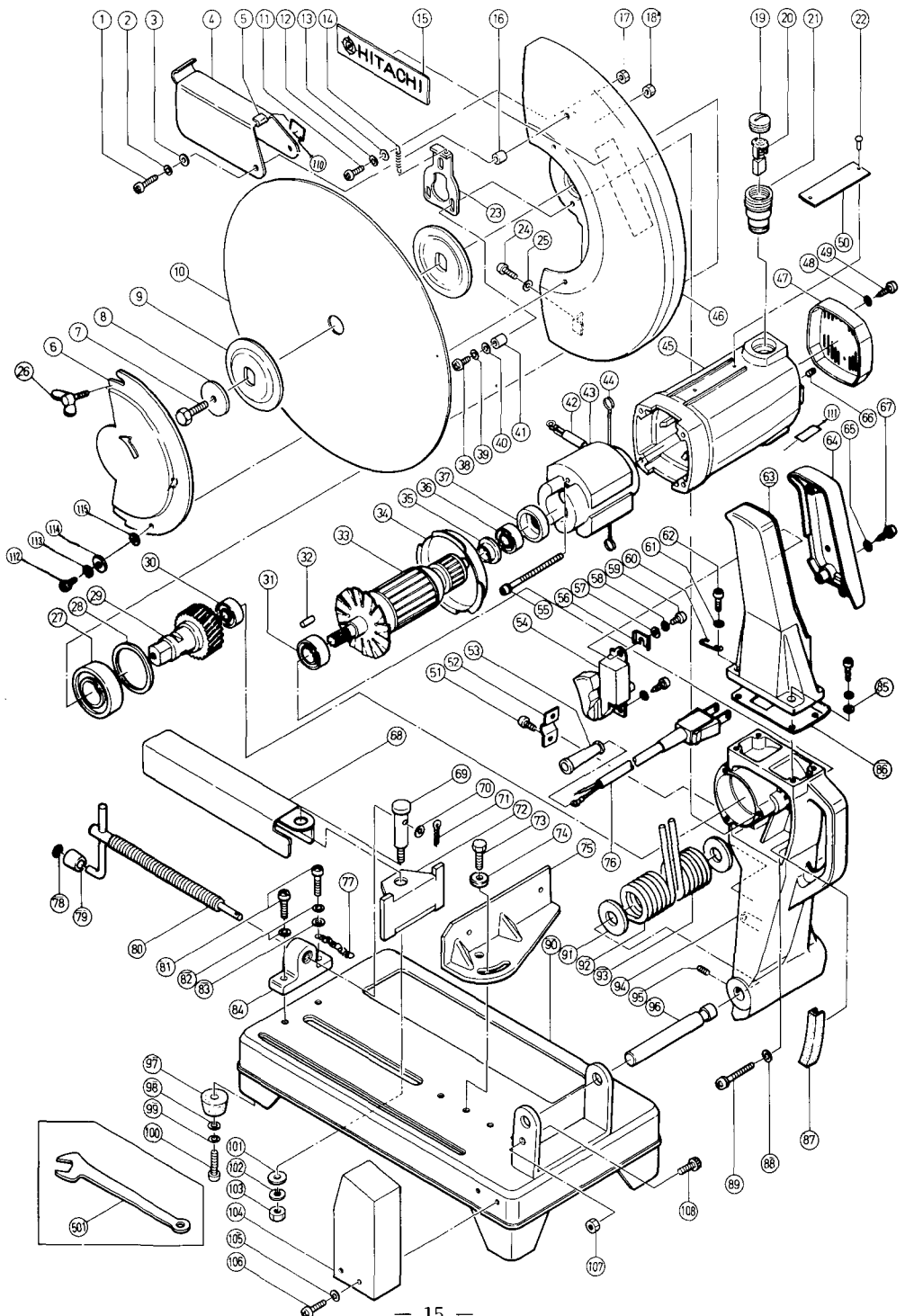

Cut Off Machine Parts List.

Item No.	Name of Parts	Item No.	Name of Parts
1	⊕Hd. Machine Screw (M6×16)	31	Ball Bearing (6202ZZCM)
2	Spring Lock Washer (M6)	32	Bearing Lock
3	Washer (H)	33	Armature Ass'y
4	Safety Cover Ass'y	34	Fan Guide
5	Cushion Rubber	35	Dust Seal
6	Sub Cover	36	Ball Bearing (6300ZZCM)
7	Screw (G)	37	Bearing Bush
8	Washer (A)	38	⊕Hd. Machine Screw (M6×22)
9	Wheel Washer	39	Spring Lock Washer (M6)
10	Wheel (A)	40	Washer (H)
11	⊕Hd. Machine Screw (M4×8)	41	Collar (F)
12	Spring Lock Washer (M4)	42	Silicone Tube (M9×1.5×285)
13	Bolt Washer (M4)	43	Stator Ass'y
14	Stopper Spring	44	Brush Terminal Ass'y
15	Decoration Name Plate	45	Housing Ass'y
16	Collar (F)	46	Wheel Cover
17	Nut (M4)	47	Tail Cover
18	Nut (M6)	48	Spring Lock Washer (M4)
19	Brush Cap	49	⊕Tapping Screw (M4×10)
20	Carbon Brush (Low Voltage)	50	Name Plate
21	Brush Holder Ass'y	51	⊕Hd. Machine Screw (M4×10)
22	Pin (2.5D×4.8)	52	Cord Clip
23	Stopper	53	Cord Armor
24	⊕Hd. Machine Screw (M5×12)	54	Trigger Switch
25	Bolt Washer (M5)	55	⊕Tapping Screw (M5×80)
26	Wing Bolt (M6×10)	56	—
27	Ball Bearing (6206ZZCM)	57	—
28	Bearing Collar	58	Spring Lock Washer (M4)
29	Spindle Ass'y	59	⊕Tapping Screw (M4×10)
30	Ball Bearing (6201ZZCM)	60	Chain Hook

Item No.	Name of Parts	Item No.	Name of Parts
61	Spring Lock Washer (M6)	91	Bolt Washer (M6)
62	⊕Hd. Machine Screw (M6×20)	92	Spring (B)
63	Switch Handle	93	Spring (A)
64	Handle Cover	94	Gear Case
65	Bolt Washer (M4)	95	Hexagon Socket Hd. Set Screw (M5×6)
66	Slotted Set Screw (M4×5)	96	Shaft
67	⊕Tapping Screw (M4×20)	97	Base Rubber
68	Screw Cover	98	Bolt Washer (M6)
69	Bolt (H)	99	Spring Lock Washer (M6)
70	Bolt Washer (M8)	100	⊕Hd. Machine Screw (M6×16)
71	Split Pin (3×15)	101	Washer (A)
72	Vise (A)	102	Spring Lock Washer (M10)
73	Bolt (M10×20)	103	Nut (M10)
74	Bolt Washer (M10)	104	Spark Chute
75	Vise (B)	105	Spring Lock Washer (M5)
76	Cord Ass'y	106	⊕Hd. Machine Screw (M5×10)
77	Chain	107	Nut (M8)
78	E-Type Retaining Ring (M6)	108	Hexagon Socket Hd. Bolt (M8×16)
79	Collar	109	Screw Vice Ass'y
80	Screw Ass'y	110	Caution Label (A)
81	⊕Hd. Machine Screw (M8×30)	111	Caution Label
82	Spring Lock Washer (M8)	112	⊕Hd. Machine Screw (M6×10)
83	Washer (M8)	113	Spring Lock Washer (M6)
84	Internal Thread	114	Washer (H)
85	Bolt Washer (M6)	115	Washer
86	Switch Plate		
87	Rubber Edge		
88	Bolt Washer (M6)		
89	⊕Tapping Screw (M5×50)		
90	Base Ass'y	501	Spanner

— MEMORANDUM

Hitachi Koki Co.,Ltd.

Nippon Bldg., 2-6-2,
Ohtemachi, Chiyoda-ku,
Tokyo 100, Japan