

HITACHI

NIBBLER MODEL CN 16

INSTRUCTION MANUAL

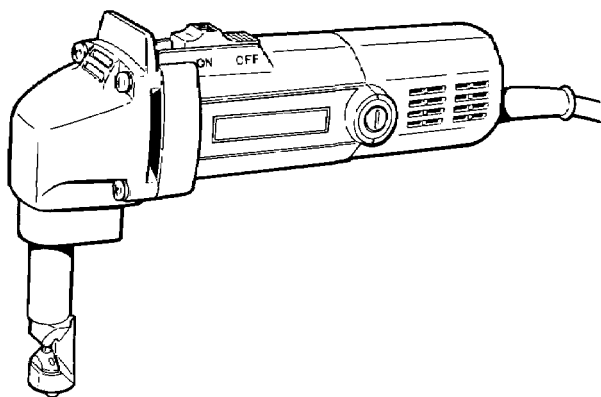

Note:

Before using this Electric Power Tool, carefully read through this INSTRUCTION MANUAL to ensure efficient, safe operation. It is recommended that this MANUAL be kept readily available as an important reference when using this power tool.



DOUBLE INSULATION

We sincerely thank you for selecting a HITACHI ELECTRIC POWER TOOL. To operate this electric power tool safely and efficiently, please read this INSTRUCTION MANUAL carefully to get a good understanding of the precautions in operation, capacity of the electric power tool, use and the like.

IMPORTANT INFORMATION: SAFETY RULES FOR POWER TOOLS

WARNING: When using electric tools, basic safety precautions should always be followed to reduce the risk of fire, electric shock, and personal injury, including the following.

READ ALL INSTRUCTIONS

- 1. KEEP WORK AREA CLEAN.** Cluttered areas and benches invite injuries.
- 2. CONSIDER WORK AREA ENVIRONMENT.**
 - Don't expose power tools to rain.
 - Don't use power tools in damp or wet locations.
 - Keep work area well lit.
 - Don't use tool in presence of flammable liquids or gases.
 - Power tools produce sparks during operation. They also spark when switching ON/OFF. Never use power tools in dangerous sites containing lacquer, paint, benzine, thinner, gasoline, gases, adhesive agents, and other materials which are combustible or explosive.
- 3. GUARD AGAINST ELECTRIC SHOCK.** Prevent body contact with grounded surfaces. For example; pipes, radiators, ranges, refrigerator enclosures.
- 4. KEEP CHILDREN AWAY.** Do not let visitors contact tool or extension cord.
 - All visitors should be kept away from work area.
- 5. STORE IDLE TOOLS.** When not in use, tools should be stored in dry, and high or locked-up place-out of reach of children.
- 6. DON'T FORCE TOOL.** It will do the job better and safer at the rate for which it was intended.
- 7. USE RIGHT TOOL.** Don't force small tool or attachment to do the job of a heavy-duty tool.
 - Don't use tool for purpose not intended – for example – don't use circular saw for cutting tree limbs or logs.
- 8. DRESS PROPERLY.** Do not wear loose clothing or jewelry. They can be caught in moving parts.
 - Rubber gloves and none-skid footwear are recommended when working outdoors.
 - Wear protective hair covering to contain long hair.
- 9. USE SAFETY GLASSES.** Also use face or dust mask if cutting opera-

tion is dusty.

All persons in the area where power tools are being operated should also wear safety eye protectors and face or dust masks.

10. **DON'T ABUSE CORD.** Never carry tool by cord or yank it to disconnect from receptacle. Keep cord from heat, oil, and sharp edges.
11. **SECURE WORK.** Use clamps or a vise to hold work. It's safer than using your hand and it frees both hands to operate tool.
12. **DON'T OVERREACH.** Keep proper footing and balance at all times.
13. **MAINTAIN TOOLS WITH CARE.** Keep tools sharp and clean for better and safer performance.

Follow instructions for lubricating and changing accessories.

Inspect tool cords periodically and if damaged, have repaired by authorized service facility.

Inspect extension cords periodically and replace if damaged.

Keep handles dry, clean, and free from oil and grease.

14. **DISCONNECT TOOLS.** When not in use, before servicing, and when changing accessories, such as blades, bits, cutters.
15. **REMOVE ADJUSTING KEYS AND WRENCHES.** Form habit of checking to see that keys and adjusting wrenches are removed from tool before turning it on.
16. **AVOID UNINTENTIONAL STARTING.** Don't carry plugged-in tool with finger on switch. Be sure switch is off when plugging in.
17. **OUTDOOR USE EXTENSION CORDS.** When tool is used outdoors, use only extension cords intended for use outdoors and so marked.
18. **STAY ALERT.** Watch what you are doing. Use common sense. Do not operate tool when you are tired.
19. **CHECK DAMAGED PARTS.** Before further use of the tool, a guard or other part that is damaged should be carefully checked to determine that it will operate properly and perform its intended function. Check for alignment of moving parts, binding of moving parts, breakage of parts, mounting, and any other conditions that may affect its operation. A guard or other part that is damaged should be properly repaired or replaced by an authorized service center unless otherwise indicated elsewhere in this instruction manual.
Have defective switches replaced by authorized service center.
Do not use tool if switch does not turn it on and off.
20. **AVOID USING A POWER TOOL FOR APPLICATIONS OTHER THAN THOSE SPECIFIED.** Never use a power tool for applications other than those specified in the instruction manual.
21. **ENSURE SAFE OPERATION THROUGH CORRECT HANDLING.** Secure safe operation through correct handling by observing the instructions described herein.
Do not employ accessories other than those specified herein; otherwise, a hazardous condition may be created.

Never allow a power tool to be used by persons not familiar with correct handling (such as children) or by those who cannot handle the tool correctly.

- 22. CONFIRM THAT NO ITEMS SUCH AS AN ELECTRIC CABLE OR CONDUIT ARE BURIED INSIDE.** In places where live wiring may be hidden behind a wall, floor, ceiling, etc. do not hold or contact any metal parts of the tool. In such cases, metal parts could become electrically live and present a serious shock hazard.
- 23. KEEP THE RIGHT PARTS IN THE RIGHT POSITIONS.** Do not remove covers and screws which have been factory-mounted. They perform important respective roles. Keep them in the right positions.
- 24. SHOULD THE PLASTIC HOUSING OR HANDLE OF A POWER TOOL BE CRACKED OR DEFORMED, DO NOT USE IT.** Since cracked or deformed parts may lead to an operator receiving an electric shock, do not use such a power tool. Immediately have it repaired.
- 25. SECURELY MOUNT ACCESSORIES AND BLADES TO THE TOOL MAIN BODY.** Extra care must be taken when using tools on elevated location (such as a roof ladder, scaffold, or the like) to prevent injury to someone on a lower level in the event the tool and/or accessory should drop.
- 26. ALWAYS KEEP THE MOTOR AIR VENT FULLY OPENED.** A constantly open motor air vent is necessary to allow air to come in and out for cooling the motor. Do not allow it to become clogged up, even if dust is blown through it.
- 27. OPERATE POWER TOOLS AT THE RATED VOLTAGE.** Operate power tools at voltages specified on their nameplates.
- 28. NEVER TOUCH THE MOVING PARTS.** Never touch the moving parts such as blades, bits, cutters and others.
- 29. STOP OPERATION IMMEDIATELY IF ANY ABNORMALITY IS DETECTED.** Should a power tool be detected as out of order or should other abnormalities be observed during operation, stop using the tool immediately.
- 30. NEVER LEAVE TOOL RUNNING UNATTENDED. TURN POWER OFF.** Don't leave tool until it comes to a complete stop.
- 31. CAREFULLY HANDLE POWER TOOLS.** Should a power tool be dropped or struck against hard materials inadvertently, it may be deformed, cracked, or damaged.
- 32. DO NOT WIPE PLASTIC PARTS WITH SOLVENT.** Solvents such as gasoline, thinner, benzene, carbon tetrachloride, and alcohol may damage and crack plastic parts. Do not wipe them with such solvents. Wipe plastic parts with a soft cloth lightly dampened with soapy water.
- 33. WHEN REPLACING A COMPONENT PART, ADOPT THE SAME TYPE.** When replacing a component part with a new one, adopt the same type of new part. Also, never attempt to repair a power tool yourself.

SERVICE AND REPAIRS

All quality tools will eventually require servicing or replacement of parts due to wear from normal use. These operations should ONLY be performed by an AUTHORIZED HITACHI POWER TOOL REPAIR SHOP.

REPLACEMENT PARTS

When servicing use only identical replacement parts.

POLARIZED PLUGS

To reduce the risk of electric shock, this equipment has a polarized plug (one blade is wider than the other).

This plug will fit in a polarized outlet only one way.

If the plug does not fit fully in the outlet, reverse the plug.

If it still does not fit, contact a qualified electrician to install the proper outlet.

Do not change the plug in any way.

EXTENSION CORD

Make sure your extension cord is in good condition. When using an extension cord, be sure to use one heavy enough to carry the current your product will draw. An undersized cord will cause a drop in line voltage resulting in loss of power and overheating. Table shows the correct size to use depending on cord length and nameplate ampere rating. If in doubt, use the next heavier gage. The smaller the gage number, the heavier the cord.

MINIMUM GAGE FOR CORD SETS

		Total Length of Cord in Feet (Meter)			
		0-25 (0-7.6)	26-50 (7.9-15.2)	51-100 (15.5-30.5)	101-150 (30.8-45.7)
Ampere More Than	Rating Not More Than	AWG			
	0-6	18	16	16	14
	6-10	18	16	14	12
	10-12	16	16	14	12
	12-16	14	12	Not Recommended	

DOUBLE INSULATION SYSTEM ENHANCES SAFE OPERATION

To enhance safe operation of this electric power tool, HITACHI has adopted a double insulation system. The term "double insulation" used here denotes an insulation system with two insulations physically separated and arranged between the electrically conductive material connected to the power supply and the outer frame subject to contact by the operator. Thus, the power tool is termed double insulated and both the "□" mark and "Double insulation", or either one is indicated on the name plate.



DOUBLE INSULATION

While no external grounding is required with this system, normal safety precautions as outlined in this manual must still be followed.

To maintain the effectiveness of the double insulation system, follow the precautions described below:

1. Always contact your dealer or an authorized HITACHI service agent when assembling, disassembling or replacing parts other than accessories or carbon brushes. Improper assembly and/or replacement with wrong parts may result in eliminating the double insulation-feature.
2. Clean the exterior of the tool with a soft cloth moistened with soapy water, and dry thoroughly. Chloric solvent, gasoline, and thinner will cause plastic components to dissolve.

PRECAUTIONS ON USING NIBBLER

1. Beware of sharp panel edges. The edge of the plate just cut by the nibbler is very sharp. Take care in not getting hurt by the sharp edge.
2. If cut material gets into the machine, it will produce problems or accidents. Do not place the machine on the cut materials.
3. Cut materials are hot immediately after they are cut. Never touch them with bare hands.
4. Preserve the power cord. Be sure that the power cord is not abraded or cut by the sharp edge of the cut panel.

SAVE THESE INSTRUCTIONS

NAME OF PARTS

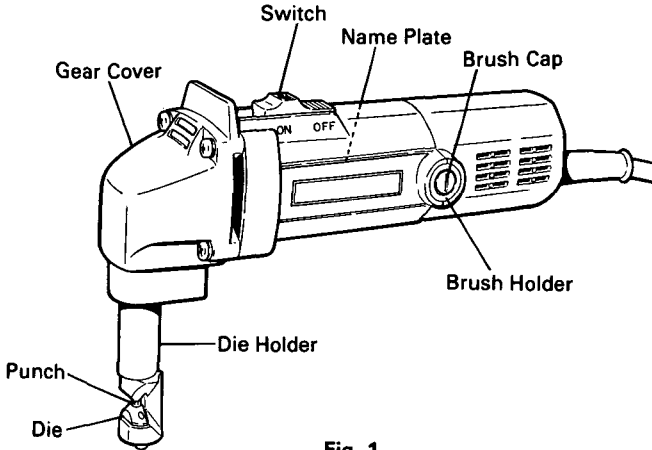

Fig. 1

SPECIFICATIONS

Motor	Single-Phase, series Commutator Motor	
Power Source	Single-Phase 115V AC 60Hz	
Input	400W	
Cutting Capacity	Mild Steel Plate	1/16" (1.6mm)
	Stainless Steel Plate	3/64" (1.2mm)
	Aluminum plate	3/32" (2.3mm)
Number of strokes at no-load	2000/min	
Minimum cutting radius	1- 5/8" (40mm)	
Width of nibbling groove	3/16" (5mm)	
Weight	3.8 lbs (1.7kg)	

ACCESSORIES

CAUTION:

Recommended accessories for this Electric Power Tool are mentioned in this manual. The use of any other attachment or accessory might be hazardous.

STANDARD ACCESSORIES

1. Hexagon Bar Wrench (Code No. 944458) 1
2. Hexagon Bar Wrench (Code No. 990666) 1

APPLICATIONS

- Cutting and pocket cutting mild steel, stainless steel, copper and aluminum plates, corrugated plates and trapezoidal plates.

PRIOR TO OPERATION

1. Power source

Ensure that the power source to be utilized conforms to the power requirements specified on the product nameplate.

2. Power switch

Ensure that the power switch is in the OFF position. If the plug is connected to a power receptacle while the power switch is in the ON position, the power tool will start operating immediately, inviting serious accident.

3. Extension cord

When the work area is removed from the power source, use an extension cord of sufficient thickness and rated capacity. The extension cord should be kept as short as practicable.

4. Die Inspection

Inspect for looseness the M8 hexagon socket set screw used for mounting the die holder, the M3 machine screws used for mounting the die (see Fig. 4) and the M5 hexagon socket set screw used for mounting the punch (see Fig. 7). Caution should be exercised because, if any of these screws are loose, not only does cutting performance deteriorate but the machine can also be damaged.

5. Lubrication

Before use, carefully lubricate the sliding surfaces around the die and punch (see Fig. 1) with a suitable amount of machine oil.

CUTTING

CAUTION:

- Never try to cut materials that are too large for the capacity of the machine since this may cause damage.
- Applying cutting oil (spindle oil, machine oil, and so on) along the shearing line may decrease wear of the punch and die.

Use care to prevent cutting oil adhering to the housing since the surface may be damaged.

1. Cutting plates

As shown in Fig. 2, hold the plates being cut parallel with the machine and apply a light force while cutting. When pocket cutting, make a hole $29/32''$ (23mm) in diameter or larger, as shown in Fig.3, and start cutting with the tip of the die holder.

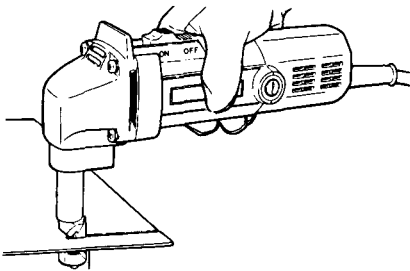

Fig. 2

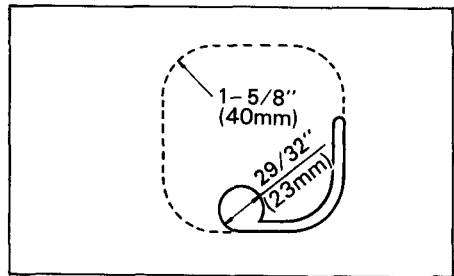

Fig. 3

2. Cutting corrugated and trapezoidal plates

- (1) The cutting direction of this machine can be rotated in 90° increments in 3 directions (A, B and C) (see Fig. 4) by loosening the M8 hexagon socket set screw mounting the die holder. Set the cutting direction in the B or C direction to cut trapezoidal plates. After that, securely tighten the M8 hexagon socket set screw.
- (2) Grip the machine firmly with both hands as shown in Fig. 5., align with the shape of the trapezoidal plate, push the machine forward until the die holder is at right angles as shown in Fig. 6 and make the cut.

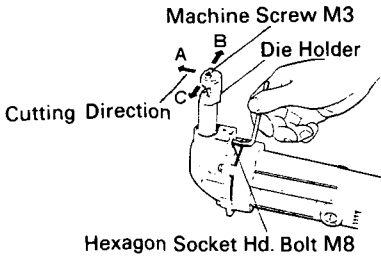

Fig. 4

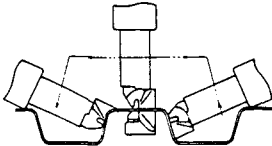

Fig. 6

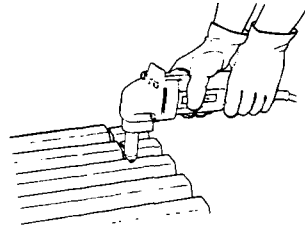

Fig. 5

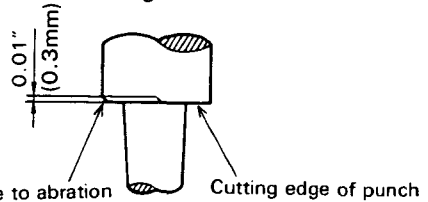

Fig. 7

REPLACING PUNCH AND DIE

CAUTION:

In this case, be sure to previously disconnect the plug from the power supply:

1. Service Life of the Punch and Die

Wear and damage to the cutting edges of the punch and die can greatly influence the cutting operation. Under normal usage, the service life of the punch and die is as shown in the table below. Replace the punch and die promptly when the end of the service life approaches. The punch and die should be replaced at the same time.

Cutting materials	Service life cutting lengths of punch and die
1/16" (1.6mm) Mild steel plates	1000ft (300m)
1/16" (1.6mm) Mild steel corrugated and trapezoidal plates	160ft (50m)
3/64" (1.2mm) Stainless steel plates	650ft (200m)

When the machine is used according to the service life indicated in the above table, the punch will have abrasions as shown in the enlarged diagram of the worn punch in Fig. 7. This is when the punch and die should be replaced.

CAUTION:

If the punch and die are used longer than the specified service life, the die holder will be subject to excessive stress and may break off.

When a 1/16" (1.6mm) mild steel trapezoidal plate is cut, wear will be especially quick. Replace the punch and die as soon as possible after reaching the service life.

2. Punch and die replacement (see Fig. 8)

Caution: During the following operations, use care to prevent dirt adhering inside the gear cover, inside the die holder and around the piston.

(1) Punch replacement

- (a) Loosen the M8 hexagon socket set screw mounting the die holder (see Fig. 4) and remove the die holder.
- (b) Loosen the M5 hexagon socket set screw fastening the punch to the piston and pull out the punch.
- (c) Insert the new punch while aligning the taper hole of the punch and the direction of the M5 hexagon socket set screw, then securely tighten the hexagon socket set screw. (see Fig. 9)

(2) Die replacement

Loosen the 2 machine screws and replace the die.

(3) Lubrication

When the above replacement operations are completed, apply a suitable amount of machine oil to the sliding surfaces around the punch and die and operate the machine without a load.

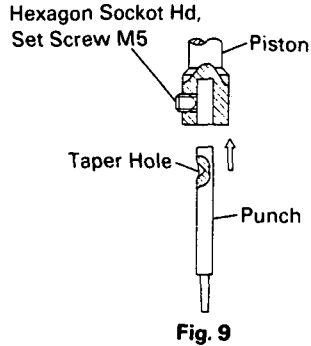
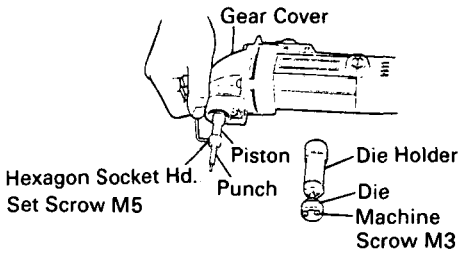

MAINTENANCE AND INSPECTION

Caution: Be sure to disconnect the plug during maintenance and inspection.

1. Checking punch and die

A worn or defective punch and die will greatly decrease work efficiency. Check and replace them periodically. Refer to "Replacing punch and die".

2. Inspecting the mounting screws

Regularly inspect all mounting screws and ensure that they are properly tightened. Should any of the screws be loose, retighten them immediately. Failure to do so could result in serious hazard.

3. Maintenance of the motor

The motor unit winding is the very "heart" of the power tool. Exercise due care to ensure the winding does not become damaged and/or wet with oil or water.

4. Inspecting the carbon brushes (Fig. 10)

The motor employs carbon brushes which are consumable parts. Since an excessively worn carbon brush could result in motor trouble, replace the carbon brush with a new one which has the same carbon brush No. shown in the figure when it becomes worn to or near the "wear limit." In addition, always keep carbon brushes clean and ensure that they slide freely within the brush holders.

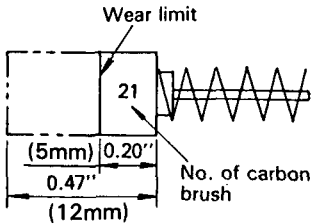

5. Replacing a carbon brush

Disassemble the brush cap with a minus-head screwdriver. The carbon brush can then be easily removed.

NOTE:

Due to HITACHI's continuing program of research and development, the specifications herein are subject to change without prior notice.

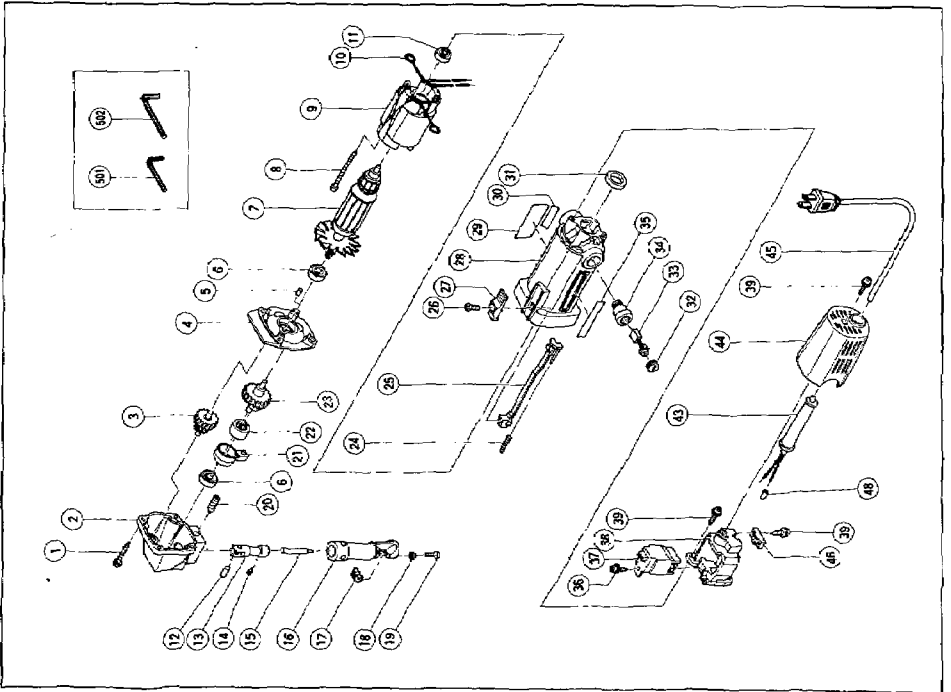

Item No.	Part Name	Item No.	Part Name
1	Tapping Screw D5 x 30	17	Die
2	Gear Cover	18	Die Holder
3	Second Pinion Gear	19	Spring Lock Washer
4	Inner Cover	20	Machine Screw M3 x 14
5	Bearing Lock	21	Hexagon Socket Hd. Set Screw M8 x 20
6	Ball Bearing (608VV/C2FS2-L)	22	Connecting Rod Ass'y
7	Armature	23	Needle Bearing (M152112)
8	Tapping Screw D4 x 60	24	Spindle
9	Stator Ass'y	25	Spring
10	Brush Terminal	26	Slide Bar
11	Ball Bearing (626VV/C2FS2-L)	27	Flat Hd. Screw M4 x 12
12	Pin D6	28	Slide Switch Knob (B)
13	Piston M3 x 14	29	Housing Ass'y
14	Hexagon Socket Hd. Set Screw M8 x 6	30	Name Plate
15	Punch	31	Bearing Bushing
16	Die	32	Brush Cap
17	Die	33	Carbon Brush
18	Spring Lock Washer	34	Brush Holder
19	Machine Screw M3 x 14	35	HITACHI Label
20	Hexagon Socket Hd. Set Screw M8 x 20		
21	Connecting Rod Ass'y		
22	Needle Bearing (M152112)		
23	Spindle		
24	Spring		
25	Slide Bar		
26	Flat Hd. Screw M4 x 12		
27	Slide Switch Knob (B)		
28	Housing Ass'y		
29	Name Plate		
30	Bearing Bushing		
31	Bearing Bushing		
32	Brush Cap		
33	Carbon Brush		
34	Brush Holder		
35	HITACHI Label		

Item No.	Part Name	Item No.	Part Name
36	Tapping Screw D4 x 12	46	Cord Clip
37	Slide Switch	48	Tube (D)
38	Switch Holder	501	Hexagon Bar Wrench
39	Tapping Screw D4 x 16	502	Hexagon Bar Wrench 4mm
43	Cord Armor		
44	Tail Cover		
45	Card		

Parts are subject to possible modification without notice due to improvements.

Issued by

Hitachi Koki Co., Ltd.

Shinagawa Intercity Tower A, 15-1, Konan 2-chome,
Minato-ku, Tokyo 108-6020, Japan

Distributed by

Hitachi Koki U.S.A., Ltd.

3950 Steve Reynolds Blvd.
Norcross, GA 30093

Hitachi Koki Canada Co.

6395 Kestrel Road
Mississauga ON L5T 1Z5

005

Code No. C99009363 N

Printed in Japan